

SEA 1612C

Antenna Tuner

- State-of-the-art microprocessor-based
- Usable with any SSB transceiver
- Compensates for antenna changes
- Special Features: Duplex Mode, Tune Lockout, and Demand Tune
- Automatic self tuning
- No presets or adjustments
- Reduces installation costs



Designed and produced in the USA by SEA, an industry leader in high technology communications equipment, the SEA 1612C automatic MF/HF tuner combines the sophistication of advanced microprocessor techniques with high order practicality and operational reliability. The SEA 1612C is housed in a weatherproof molded case designed to withstand rugged environmental conditions encountered aboard ship while mounted on the external weather decks.

WHY AN ANTENNA TUNER?

An antenna of fixed length is often used with HF/SSB equipment that covers a wide frequency range so that an antenna tuner is necessary if optimum efficiency is to be obtained. Two types of tuners are available, fixed and automatic tuned. Fixed-tuned type couplers must be pre-adjusted by a technician at each frequency to be used so that the number of channels is limited by practical considerations. An automatic coupler is a necessity with modern multi-channel MF/HF SSB transceivers like the SEA 235 and SEA 245G. Also excellent for land mobile installations, SEA 1612C is capable of tuning a nine (9) foot (2.7M) whip over a frequency range of 4 to 30 MHz.

AUTOMATIC TUNER OPERATIONS

The SEA 1612C is a versatile, fully automatic microprocessor-based antenna tuner. Upon the first voice impulse, the transceiver initiates a rapid microprocessor controlled search/match procedure that determines antenna characteristics and inter-connects the proper elements for optimum match and power transfer.

SEA 1612C HAS A MIND OF ITS OWN!

The internal computer in this tuner has "learning" capability that remembers which network constants were set in for a particular frequency. This information is stored in computer memory and is recalled instantly whenever the same frequency is again selected. SEA 1612C will "relearn" and compensate automatically for minor changes in the antenna system.

Equipment will operate properly on low power inputs (15 to 20 watts), and will provide an infinite number of channels within its specified frequency range (see specifications).

The SEA 1612C also includes these features:

Duplex Mode makes use of a special control algorithm which, when energized, senses the RECEIVE mode and switches out all tuning elements.

Tune Lockout feature is useful when two or more transmitters are co-located, or when it is desirable to inhibit the AUTO TUNE function for any reason.

Demand Tune function allows the user to force the antenna tuner to retune on demand. This permits "overwriting" previously stored tuneup information when desired.

The SEA 1612C is also available with optional antenna grounding relay. Contact the factory for further information.

Specifications:

Frequency Range:

1.6 to 30 MHz

RF Power Handling Capability:

150 watts, PEP maximum

Tuning Time: "Learn" mode

Less than 5 seconds (typical)

Internal Matching Networks

Microprocessor controlled, "Pi" or "L"

Input Impedance:

50 ohms

VSWR:

<2:1

Frequency Tuning Range for Land Mobile

Applications Using 9 ft (2.7M) Whip:

3 to 30 MHz

Usable Antenna Lengths:

23 to 75 ft (nom) (7 to 23 M)

Power Requirements:

13.6 VDC @ 300ma typical,
2.0 amps maximum

Control Cable:

No. 20 GA, 3 to 5 conductor, shielded cable

Environmental Temperature Range:

-30°C to +60°C

Dimensions:

Inches: 16 x 12 x 3.9

MM: 381 x 304.8 x 99

Weight:

10 pounds / 4.5 Kg.

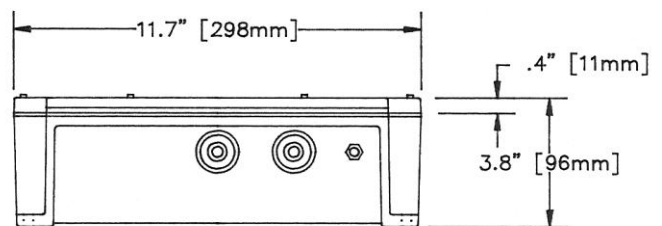
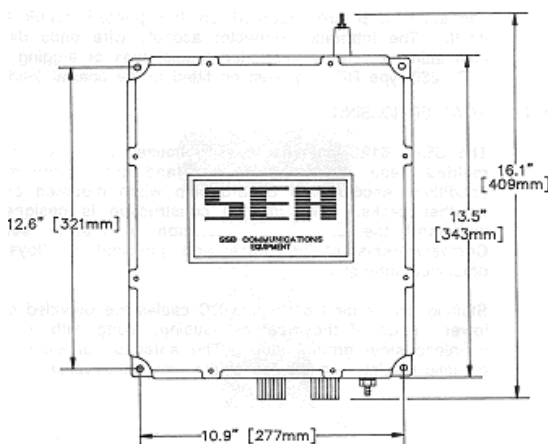

SEA COM CORPORATION

7030 - 220th S.W., Mountlake Terrace, Washington 98043, 425.771.2182 Fax: 425.771.2650 www.seacomcorp.com